

GAT ECO.Lock

Battery-Powered Electronic Locker Lock



© Copyright 2025 Gantner Electronic GmbH

Operating instructions, manuals and software are protected by copyright. All rights are reserved. Copying, duplication, translation, installation in any electronic medium or machine-readable form in whole or in part is prohibited. The sole exception is represented by creation of a back-up copy of software for own use as a safeguard, so far as this is technically possible and recommended by us. Any infringement will render the party committing such infringement liable to compensation payment.

Liability

Any claims against the manufacturer based on the hardware or software products described in this manual shall depend exclusively on the conditions of the guarantee. Any further-reaching claims are excluded, and in particular the manufacturer accepts no liability for the completeness or accuracy of the contents of this manual. The right is reserved to make alterations, and alterations may be made at any time without prior notice being given.

Trademarks

Attention is drawn at this point to markings and registered trademarks used in this manual. All product and company names, which are mentioned in this manual, are only used for identification and explanation purposes. Some of these names may be trademarks or registered trademarks of the corresponding company.

Contact

If you have any questions regarding this product, please contact your local representative or one of the Gantner Electronic GmbH branches directly. The contact addresses can be found using the following link:

www.gantner.com/en/locations

Contact address of manufacturer

Gantner Electronic GmbH
Bundesstraße 12
6714 Nüziders, Austria

Important Informationen

Dear Customer,

Our aim is to ensure that our product operates with safety and to your complete satisfaction. To achieve this aim, please take this opportunity to familiarize yourself with the following guidelines.

- > Pay attention to the safety messages in this manual. The messages are indicated by the signal words "DANGER", "WARNING", or "CAUTION", and inform you about hazardous situations and how to avoid them.
- > Pay attention to messages indicated by the "NOTICE" signal word. These messages include important information for avoiding property damage.
- > Pay attention to the symbols and safety messages on the product.
- > Read all instructions in this manual carefully before installing or operating the product.
- > Where not otherwise specifically documented, the appropriate installation, commissioning, operation, and maintenance of the product is the customer's responsibility.
- > Keep this manual in a safe place for quick reference.

Notation of Safety Information and Safety Symbols

This manual includes important safety messages and symbols intended to inform the user about potentially hazardous situations or important information for the safe and proper use of the described product(s). The safety messages also include directives on how to avoid hazardous situations. These safety messages and directives must be read and observed.

The structure of the safety messages and the meaning of the symbols used in this manual are described in this section.

1. Safety Messages for Personal Injury

Personal safety messages contain a signal word, describe the nature of the hazard, and indicate how to avoid the hazard.



The safety alert symbol used without a signal word always precedes important safety information that must be read carefully, and the instructions carefully observed. Not doing so may cause personal injury.

Format of safety messages that apply to an entire section:

These safety messages may be used with or without a symbol.

⚠ CAUTION



Electrical shock

- ➔ *Touching current-conducting parts may result in injury due to electrical shock.*
- *Do not remove safety protection and covers.*
- *Do not touch the electrical connections while power is being supplied.*

Format of safety messages that are embedded in text and apply to a specific point:



CAUTION! Electrical shock. Never remove safety protection and covers. Do not touch the electrical connections while power is being supplied.

2. Property Damage Messages

Property damage messages are used to describe potentially hazardous situations that may lead to property damage. These messages have the same layout as safety messages but use the signal word "NOTICE" instead of "CAUTION".

Format of property damage messages that apply to an entire section:

NOTICE



Risk of damage to the device and connected devices
Risk of malfunction

- Read the following instructions carefully before installing the device.
- Always adhere to the instructions.





Format of property damage messages that are embedded in text and apply to a specific point:







NOTE! Risk of damage to the device and connected devices. Read the following instructions carefully before installing the device.

3. Definition of the Signal Words

	Indicates a hazardous situation that, if not avoided, may result in minor or moderate injury.
	Indicates information considered important, but not hazard-related (e.g., messages relating to property damage).

4. Definition of the Safety Symbols

	Caution: General Information This symbol indicates general warnings or cautions that are not related to a particular type of hazard.
	Caution: Electrical Shock This symbol indicates warnings related to electrical hazards (danger due to high voltage).
	Prohibited: Do Not Disassemble This symbol indicates warnings about not disassembling certain components or equipment. Disassembling may lead to damage or malfunction of the device.
	Mandatory Action: General Information This symbol indicates general information that must be read and followed before proceeding with the accompanying instructions.
	Mandatory Action: Read Instructions This symbol indicates information referring to an important description in the manual, or other documentation, which must be read and followed.

 Important Safety Information 	
 	<ul style="list-style-type: none"> - The installation, commissioning, and servicing of our products must be performed only by suitably trained personnel. In particular, electrical connections must only be made by correspondingly qualified specialists. Always observe the relevant installation regulations in accordance with the national Electrical Engineers Association. <ul style="list-style-type: none"> ➔ Unqualified personnel may potentially perform actions that result in injury due to electrical shock). - Where not otherwise stated, installation and maintenance work on our products must be carried out when disconnected from the power supply. This applies in particular to appliances that are normally supplied by low-voltage current. <ul style="list-style-type: none"> ➔ If the appliance is not disconnected from power, touching terminals or other internal parts of the appliance may lead to injury due to electrical shock).
	<ul style="list-style-type: none"> - It is prohibited to alter the products (devices, cabling, etc.): <ul style="list-style-type: none"> ➔ Alterations to the products may subsequently result in personal injury, property damage, or damage to the products. - Do not remove protective shields and covers. <ul style="list-style-type: none"> ➔ Removing protective shields and covers may result in personal injury or property damage. - Do not attempt to repair a product after a defect, failure, or damage is detected. In addition, do not put the product back into operation. In such cases, it is essential to contact your GANTNER representative or the GANTNER support hotline.
 	<ul style="list-style-type: none"> - The installation, commissioning, operation, and maintenance of the product must be carried out in accordance with the technical conditions of operation as described in the corresponding documentation. Therefore, it is essential to read the corresponding chapter of this manual and observe the instructions and information therein. - If there are still some points that are not entirely clear, please do not take a chance. All queries can be clarified by your GANTNER representative or by ringing the GANTNER support hotline. - Directly on receipt of the goods, inspect both the packaging and the product itself for any signs of damage. Also check that the delivery is complete and includes all accessories, documentation, auxiliary devices, etc.. - If the packaging or product has been damaged in transport, or should you suspect that it may have a fault, the product must not be put into service. Contact your GANTNER representative who will endeavor to resolve the problem as quickly as possible. - Unless otherwise specified, the customer is responsible for the proper installation, commissioning, operation and maintenance of the product. - GANTNER Electronic GmbH accepts no responsibility for any injuries or damage caused as a result of improper use.

Although great care is taken and we are continuously aiming for improvement, we cannot completely exclude the possibility of errors appearing in our documentation. GANTNER Electronic GmbH therefore accepts no responsibility for the completeness or the accuracy of this manual. The right is reserved to make alterations at any time without prior notice.

Should you discover any fault with the product or in its accompanying documentation, or you have any suggestions for improvement, you may confidently inform your GANTNER representative or GANTNER Electronic GmbH directly.

We especially look forward to hearing from you if you want to let us know that everything is functioning perfectly.

The GAT ECO.Lock locks have been developed and manufactured under the ISO 9001 quality management standard and GANTNER Electronic GmbH is also certified according to standard ISO 14001.



This product is in conformity with the following EC directives, including all applicable amendments:
- 2014/53/EU (Radio Equipment Directive)
The complete text of the CE Declaration of Conformity is available on the following internet link:
https://www.gantner.com/en/gr_oGgFB2mqZc



GANTNER is committed to meeting or exceeding the requirements of the RoHS directive (2011/65/EU). The RoHS directive requires that manufacturers eliminate or minimize the use of lead, mercury, hexavalent chromium, cadmium, polybrominated biphenyls and polybrominated diphenyl ethers in electrical and electronic equipment sold in the EU after July 1, 2006.



The WEEE symbol on GANTNER products and their packaging indicates that the corresponding material must not be disposed of with normal household waste. Instead such marked waste equipment must be disposed of by handing it over to a designated electronic waste recycling facility. Separating and recycling this waste equipment at the time of disposal will help to conserve natural resources and ensure that it is recycled in a manner that protects human health and the environment. Please contact your local authority for further details of your nearest electronic waste recycling facility.

RF exposure statement

The users must keep at least 20 cm separation distance from the lock, except during the identification and operation process at the lock, which must be performed as described in this manual.



FCC INFORMATION (U.S.A.)

Note

This equipment has been tested and found to comply with the limits for a Class B digital device, pursuant to part 15 of the FCC Rules. These limits are designed to provide reasonable protection against harmful interference in a residential installation. This equipment generates, uses, and can radiate radio frequency energy and, if not installed and used in accordance with the instructions, may cause harmful interference to radio communications. However, there is no guarantee that interference will not occur in a particular installation. If this equipment does cause harmful interference to radio or television reception, which can be determined by turning the equipment off and on, the user is encouraged to try to correct the interference by one or more of the following measures:

- Reorient or relocate the receiving antenna.
- Increase the separation between the equipment and receiver.
- Connect the equipment into an outlet on a circuit different from that of which the receiver is connected.
- Consult the dealer or an experienced radio/TV technician for help.

FCC Warning Statement

[Any] changes or modifications not expressly approved by the party responsible for compliance could void the user's authority to operate the equipment.

Compliance Statement

This device complies with Part 15 of the FCC Rules.
Operation is subject to the following two conditions:
(1) This device must not cause harmful interference, and,
(2) this device must accept any interference received,
including interference that may cause undesired operation.

INDUSTRY CANADA INFORMATION

This device contains licence-exempt transmitter(s)/receiver(s) that comply with Innovation, Science and Economic Development Canada's licence-exempt RSS(s). Operation is subject to the following two conditions:

- (1) This device may not cause interference.
- (2) This device must accept any interference, including interference that may cause undesired operation of the device.

L'émetteur/récepteur exempt de licence contenu dans le présent appareil est conforme aux CNR d'Innovation, Sciences et Développement économique Canada applicables aux appareils radio exempts de licence. L'exploitation est autorisée aux deux conditions suivantes:

- (1) l'appareil ne doit pas produire de brouillage;
- (2) l'appareil doit accepter tout brouillage radioélectrique subi, même si le brouillage est susceptible d'en compromettre le fonctionnement.

Dieses Gerät erfüllt die Anforderungen nach Industry Canada's licence-exempt RSSs. Der Betrieb unterliegt den folgenden zwei Bedingungen:

1. Dieses Gerät darf keine Störungen verursachen; und
2. Dieses Gerät muss alle Störungen akzeptieren, einschließlich solcher, die einen unerwünschten Betrieb des Gerätes verursachen können.

ICES Statement (Canada)

This Class B digital apparatus complies with Canadian ICES-003.

Cet appareil numérique de la classe B est conforme à la norme NMB-003 du Canada.

Dieses digitale Gerät der Klasse B entspricht dem kanadischen ICES-003.



An overview of all certifications is available on the Gantner website with the following link:
https://www.gantner.com/en/qr_oGqFB2mqZc



CONTENTS

1	INTRODUCTION	11
1.1	About this manual	11
1.2	Chapter overview	11
1.3	Target group	11
1.4	Formatting	12
1.4.1	Safety-critical information	12
1.4.2	Non safety-critical information	12
1.4.3	Instructions and results	12
1.5	Contact & inquiries	12
1.6	Terminology	13
2	GENERAL INFORMATION	15
2.1	Intended use	15
2.2	Functional description	15
2.3	GAT ECO.Lock variants	16
2.4	Door labels	17
2.5	Adapter for metallic lockers	18
2.6	Door handle (optional)	18
3	INSTALLATION	19
3.1	Target group	19
3.2	Test installation	19
3.3	Replacement after break-in	19
3.4	Metallic and non-metallic doors	19
3.5	Definition of the door direction (right or left door)	20
3.6	Conversion for right- or left-hinged door	21
3.7	Requirements for the GAT ECO.Lock 715x variants (IP64)	22
3.8	Measurement diagrams for installation	23
3.8.1	Door width and thickness	23
3.8.2	Dimensions of the GAT ECO.Lock	24
3.9	Installation in lockers with non-metallic doors	25
3.9.1	Measurements for the button drill hole	25
3.9.2	Measurements for installation	26
3.9.3	Installation instructions for non-metallic doors	27
3.10	Installation in lockers with metallic doors	28
3.10.1	Measurements for the button drill hole	28
3.10.2	Measurements for installation	29
3.10.3	Installation instructions for metallic doors	30
3.11	Attaching the door labels	31
3.12	Installing the door handle	32
4	COMMISSIONING	35
4.1	Target group	35
4.2	Battery lock configuration set	35
4.2.1	GAT ECO.Basic Set	35
4.2.2	GAT DL 300 Master Key Set	36
4.3	Power supply	37
4.3.1	Battery information	37
4.3.2	Inserting the batteries	37
4.3.3	Replacing the batteries	38
4.3.4	Emergency power adapter	39

4.4	USB connection	40
5	MAINTENANCE	43
5.1	Cleaning	43
5.2	Maintenance	43
5.3	Functional testing.....	43
5.4	Disposal.....	44
6	TECHNICAL DATA	45
6.1	Power supply	45
6.2	Reading field	45
6.3	Memory and time management.....	45
6.4	Control and display elements	46
6.5	Interface	46
6.6	Housing	46
6.7	Environmental conditions	46

1 INTRODUCTION

1.1 About this manual

This manual contains the information necessary for the installation of the GAT ECO.Lock electronic locker locks. The GAT ECO.Lock is available in various variants (see chapter "2.3 GAT ECO.Lock " for more information), and the terms "GAT ECO.Lock" and "lock" are used interchangeably throughout the manual to represent all variants. If information only applies to a specific lock, the respective product name is used.



Information on the configuration and operation of the GAT ECO.Lock is available in separate manuals:

- *GANTNER Battery Locker Locks Function Manual: For all battery locker locks without OSS or CardNET functionality.*
- *GANTNER Battery Locker Locks OSS Function Manual: For all battery locker locks with OSS functionality.*
- *GANTNER Battery Locker Locks CardNET Function Manual: For all battery locker locks with CardNET functionality.*

1.2 Chapter overview

Available in chapter "2 GENERAL INFORMATION" are a functional description of the GAT ECO.Lock, information on the different lock variants, and information on the optional installation components.

Chapter "3 INSTALLATION" describes how to install the GAT ECO.Lock into the locker. Here you will find the installation procedure for the locks including all the important measurements and tips for installation.

Chapter "4 COMMISSIONING" describes how to put the GAT ECO.Lock into operation and includes information on the battery used to power the lock and the USB connection used for PC connection and configuration.

Contained in chapter "5 MAINTENANCE" are the instructions for performing functional testing and maintenance of the GAT ECO.Lock to ensure that the correct operation is maintained.

Chapter "6 TECHNICAL DATA" contains all the relevant technical information for the GAT ECO.Lock.

1.3 Target group

This manual contains information relevant for the different stages in the operating life of the lock. Information regarding the installation, commissioning, and service/maintenance is separated into corresponding chapters. When a chapter is intended for a specific audience, this is clarified at the beginning of the chapter.

Information for the following target groups is available in this manual:

- > installation technicians / locker manufacturers (installation, commissioning)
- > service technicians (service and maintenance)

Where not explicitly stated, the information in this manual is intended for all target groups in general.

⚠ CAUTION! Injury and property/equipment damage. The tasks described in each chapter must only be performed by the specified target group. Unqualified personnel who perform the described tasks risk personal injury or damaging property/equipment.

1.4 Formatting

1.4.1 Safety-critical information

The following formatting (with example text) is used in this manual to display important, safety-critical information that must be read and followed):

NOTE! Following on from this signal word in the manual is a reference text that must be read and followed. The reference text contains important information. Non-observance can lead to damage of the device or associated equipment.

1.4.2 Non safety-critical information

The following formatting (with example text) is used in this manual to display important, but not safety-critical information:



The text accompanying this symbol contains interesting information relevant to the current chapter. You do not necessarily need to read this text; however, it will help you better understand the information in this section or provide interesting tips for the described device or the operation of the software.

1.4.3 Instructions and results

Instructions, which must be completed by the reader, and the results of these instructions are formatted as follows.

- ▶ This symbol represents an action or instruction, that that must be followed.
 - This symbol represents the result after completing the previous instruction.

1.5 Contact & inquiries

For all inquiries concerning the GAT ECO.Lock, please contact your local sales partner or one of the GANTNER branch offices directly. The contact details are available via the following link: www.gantner.com/de/locations.

1.6 Terminology

Several key terms that are used often in this manual are defined below.

Computer / PC

These terms refer to all desktop and laptop computers used to configure and maintain the locks.

Data carrier

An identification medium with electronic memory and an ID number that is used by the employees and visitors of a facility for identification. Data carriers are available in a variety of different forms (e.g., chip cards, wristbands, key tags), and to suit different RFID technologies (LEGIC, MIFARE®, ISO 15693, HID iCLASS).

System data carrier

Several different types of system data carriers are used for programming, service, and maintenance tasks. These data carriers have special functions and as they are essential for operation and have security-related features, they must be kept in a secure place protected against unauthorized use. Most of the system data carriers are included in the battery lock configuration set, however, some must be ordered separately as required.

FID (Company ID) and Site Key

LEGIC systems use the FID number and in MIFARE® systems the site key is used, which is a combination of the FID and the read and write keys. The FID and site key are unique for every facility. These numbers are encoded in every data carrier and device used in the facility thereby ensuring that data carriers from one installation cannot be used in other installations.

GAT ECO Lock Configurator

A GANTNER developed PC software that is used to configure the GANTNER battery-powered locker locks.

Lock

General term for all lock variants.

Locker

The term "locker" is used to describe all possible locker applications that can be fitted with a GANTNER electronic lock. Typical applications include a changing room locker, a deposit box, or a private box.

RFID (Radio-Frequency Identification)

Identification over a short distance using radio frequency. An RFID data carrier is used to identify users in GANTNER systems.

Wireless (BLE)

Identification via a wireless interface in the range 2.402 to 2.48 GHz, over which identification and locker operation from a distance is possible, e.g., via a smartphone app. Wireless in this manual also means BLE. An additional feature is the monitoring of the lock status using an access point and the Relaxx locker management software.

User / Guest / Visitor

These general terms refer to the people in a facility who use the locker system with GANTNER locker locks, data carriers, and other GANTNER devices.

Left locker door / right locker door

Door opening direction according to DIN 107, i.e., whether the hinges or axis of rotation of the door are on the left or right when looking at the locker door. For more information see "3.5. Definition of the door direction (right or left door)".

2 GENERAL INFORMATION

2.1 Intended use

The GAT ECO.Lock may only be used for the electronic locking of lockers in facilities such as leisure facilities, universities, companies, depots, and other individual business applications. The GAT ECO.Lock is locked and unlocked using contactless RFID (Radio Frequency Identification) data carriers.

2.2 Functional description

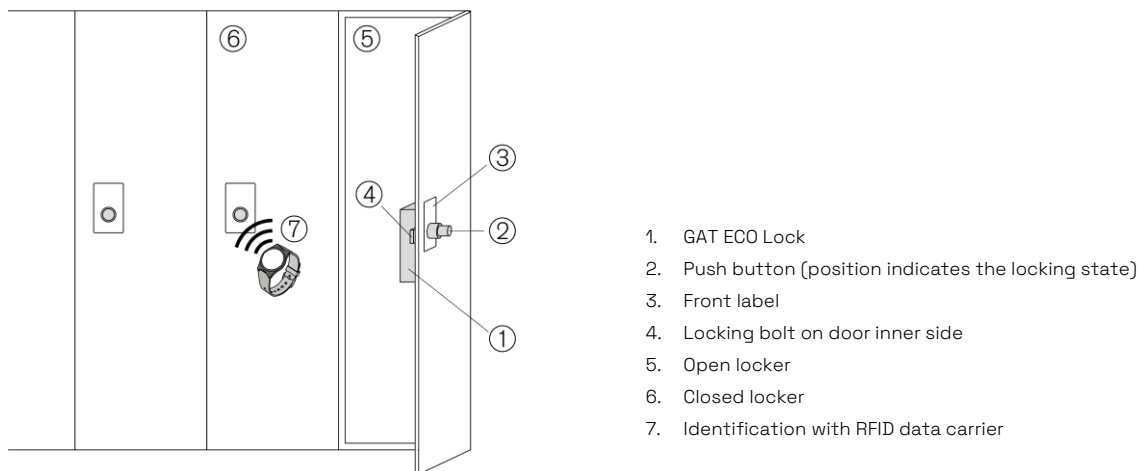

The GAT ECO.Lock is installed on the inner side of the locker door and is suitable for most types of locker material, e.g., sheet metal, wood, HPL, and solid plastic. The GAT ECO.Lock can be used with left- and right-hinged locker doors alike. Due to its mechanical compatibility with the GAT Lock 6xxx series locks and mechanically identical locks from other manufacturers, existing locker installations can be effortlessly upgraded using the GAT ECO.Lock.

The GAT ECO.Lock is powered by three 1.5 V AA alkaline batteries, which provide an operating life of up to five years* (at room temperature) before requiring replacement. For configuration, the lock connects to a computer via USB and can then be configured using GANTNER's "GAT ECO Lock Configurator" configuration software. Configuration via NFC with a mobile device and the GANTNER "MoLA" app is also possible. The lock can operate in one of five operating modes thereby providing flexibility for different locking requirements within a facility.

Using a locker

To use a locker, the user closes the door of their locker and while holding the door shut, presses the button of the GAT ECO.Lock in using their data carrier. The GAT ECO.Lock reads the data carrier information and determines whether the user is authorized to use the locker. When the user is authorized, the GAT ECO.Lock locks the locker door. The LED ring surrounding the button signals the locking action and the button remains in the pressed-in position.

To unlock a previously locked locker, the user presses their data carrier onto the lock button. The GAT ECO.Lock reads the data carrier and checks that it has valid authorization before automatically unlocking the locker door.

** Different operating modes or configurations can reduce the battery lifespan.*

2.3 GAT ECO.Lock variants

Multiple variants of the GAT ECO.Lock are available to suit different requirements, e.g., identification options. The following table provides an overview of the variants and their different functions.

Variant	Wireless ¹⁾	Outdoor IP64	RFID ²⁾
GAT ECO.Lock 7100 BA	-	-	<u>LEGIC advant reader:</u>
GAT ECO.Lock 7100 NW BA	X	-	- LEGIC prime
GAT ECO.Lock 7100 NW BA OSS ³⁾	X	-	- LEGIC advant
GAT ECO.Lock 7100 NW BA CardNET ⁴⁾	X	-	- LEGIC combi data carrier (CTC, MV, MP, MM) - MIFARE® Classic - DESFire - MIFARE Ultralight® - NFC (HCE) - HID iClass CSN (UID) 13.56 MHz - ISO 15693
GAT ECO.Lock 7100 F/ISO	-	-	<u>MIFARE / ISO 15693 reader:</u>
GAT ECO.Lock 7101 F/ISO	-	-	- MIFARE® Classic
GAT ECO.Lock 7102 F/ISO	-	-	- DESFire
GAT ECO.Lock 7100 NW F/ISO	X	-	- MIFARE Ultralight®
GAT ECO.Lock 7101 NW F/ISO	X	-	- NFC (HCE)
GAT ECO.Lock 7102 NW F/ISO	X	-	- LEGIC advant (UID)
GAT ECO.Lock 7102 NW F/ISO ICLS	X	-	- ISO 15693
GAT ECO.Lock 7150 F/ISO	-	X	- HID iClass®
GAT ECO.Lock 7151 F/ISO	-	X	Variants without "ICLS": - HID iClass® - CSN (UID) 13.56 MHz
GAT ECO.Lock 7150 NW F/ISO	X	X	Variants with "ICLS":
GAT ECO.Lock 7151 NW F/ISO	X	X	- HID iClass® - CSN (UID) 13.56 MHz
GAT ECO.Lock 7152 NW F/ISO	X	X	- HID iClass® - PACS Data 13.56 MHz - HID iClass® Seos - PACS Data 13.56 MHz

- 1) Identification via wireless BLE technology (2.402 to 2.48 GHz) over long distances of up to several meters. This option can be used, e.g., for identification at the lock using a smartphone with a specific app. An additional feature is the monitoring of the lock status using an access point and the Relaxx locker management software.
- 2) Identification via radio frequency (13.56 MHz) over a short distance of up to a few centimeters (RFID = Radio-Frequency Identification).
- 3) Available with OSS Standard Offline function. See the respective documentation for more information.
- 4) Available with CardNET function. See the respective documentation for more information.

Table 2.1 – GAT ECO.Lock variants

2.4 Door labels

After installing the lock, a label can be attached to the front of the locker door to display the locker number or provide instructions for use (see chapter “3.11. Attaching the door labels”). GANTNER offers a variety of label sizes for the GAT ECO.Lock.

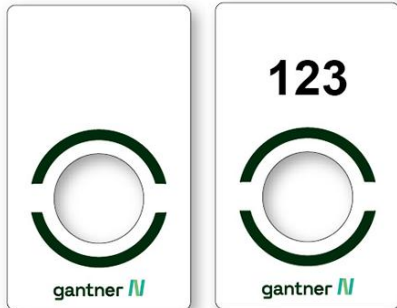

GAT ECO.Lock 71xx Label WSG (Part No. 1114519)

Self-adhesive door label in GANTNER WECO design without numbering, 23 mm cut-out for button of GAT ECO.Lock, 75 x 45 mm

GAT ECO.Lock 71xx Label WSG NUM (Part No. 1114520)

Self-adhesive door label in GANTNER WECO design with numbering, 23 mm cut-out for button of GAT ECO.Lock, 75 x 45 mm

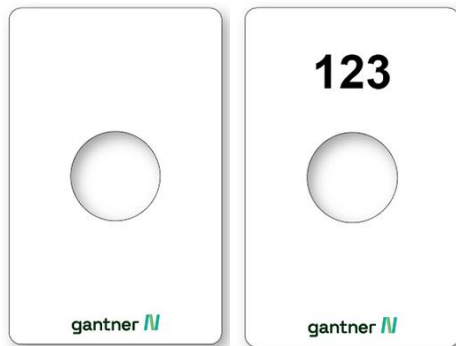

GAT ECO.Lock 71xx Label XS WSG (Part No. 1114521)

Self-adhesive door label in GANTNER WECO design without numbering, 23 mm cut-out for button of GAT ECO.Lock 71xx, 85.6 x 54 mm

GAT ECO.Lock 71xx Label XS WSG NUM (Part No. 1114522)

Self-adhesive door label in GANTNER WECO design with numbering, 23 mm cut-out for button of GAT ECO.Lock 71xx, 85.6 x 54 mm

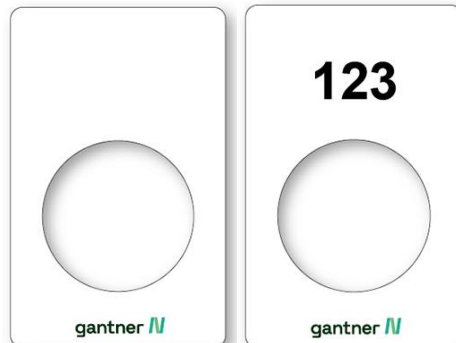

GAT ECO.Lock 72xx Label WSG (Part No. 1114523)

Self-adhesive door label in GANTNER WECO design without numbering, 38 mm cut-out for button of GAT ECO.Lock 72xx, 85.6 x 54 mm

GAT ECO.Lock 72xx Label WSG NUM (Part No. 1114524)

Self-adhesive door label in GANTNER WECO design with numbering, 38 mm cut-out for button of GAT ECO.Lock 72xx, 85.6 x 54 mm



GAT ECO.Lock 7xxx Label operation instruction - WSG (Part No. 1114525)

Self-adhesive locker door label with graphical operating instructions in GANTNER WECO design, 75 x 75 mm.



Gantner can also design and print customer-specific labels. Contact your Gantner representative for more information.

2.5 Adapter for metallic lockers

To enable the installation of the GAT ECO.Lock into metallic lockers, the **GAT ECO.Lock 7200 Adapter** (Part No. 614322) is required. A larger 38 mm cutout is required in the metallic locker door to accommodate the adapter.



See chapter "3.10. Installation in lockers with metallic doors" for the required installation instructions.

2.6 Door handle (optional)

The optional **GAT Lock Door Handle** (Part No. 610217) can be mounted onto the locker door to assist door opening. There is space on the door handle for a number label or this space can be left empty.

NOTE! The door handle cannot be used with metallic locker doors, which have a 38 mm drill hole for the GAT ECO.Lock 7200 Adapter.



See chapter "3.12. Installing the door handle" for instructions on mounting the door handle.

3 INSTALLATION

NOTE! These installation instructions describe how to install the GANTNER locker lock. Please read this section carefully prior to working on the lockers or installing the locks.

NOTICE

Risk of damage or failure to the lock

- *Read the information in this section carefully before installing the lock.*
- *Carefully observe the installation diagrams.*
- *Use the correct tools to install the lock.*

3.1 Target group

This chapter provides information for technicians responsible for installing the GAT ECO.Lock. Experience in mechanical work and basic electrical knowledge is required. Previous knowledge of GANTNER locks is not required.

3.2 Test installation

As GANTNER locks are suitable for a wide range of installation applications, always perform a test installation including functional testing of the lock in a sample locker from the facility before starting with the mass production of lockers.

Ensure that the latch of the lock slides easily in and out without resistance of the opening in the locker body. Also test that the lock locks and unlocks as required, ideally using a data carrier of the same type to be used with the locker system to ensure that the data carrier functions properly.

3.3 Replacement after break-in

If a break-in (forced opening) is attempted or occurs at a locker, the entire GAT ECO.Lock must be replaced with a new one.

3.4 Metallic and non-metallic doors

The GAT ECO.Lock is suitable for locker doors made of metal and non-metallic materials and is also suitable for indoor installations as well as outdoor installations. GANTNER provides different variants to suit these differing installation requirements. See section "2.3. GAT ECO.Lock" for more information.

The installation procedure is different for lockers with metallic doors and lockers with non-metallic doors. See sections "3.9. Installation in lockers with non-metallic doors" or "3.10. Installation in lockers with metallic doors" for the relevant installation instructions).

3.5 Definition of the door direction (right or left door)

For installation, it is important to determine whether the locker door is a "right" or "left" door. These terms are used in this manual as defined in DIN 107. Accordingly, when looking at the opening surface, i.e., the side of the door that swings open, the hinge or the axis of rotation is on the left for a left door and on the right for a right door.

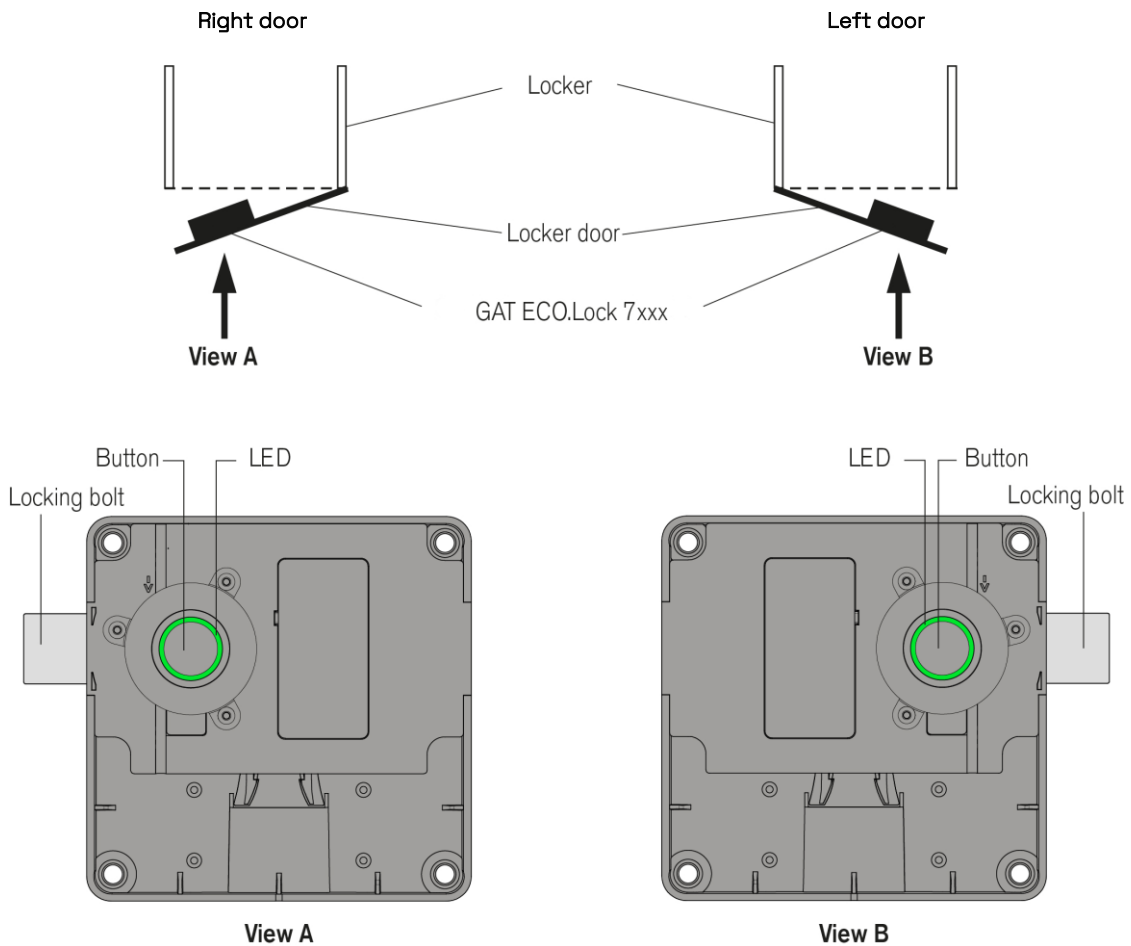

Figure 3.1 – Locker door hinge definition (left / right)

The position of the locking bolt and button of the GAT ECO.Lock is different for right and left-hinged doors. The switch from left to right door operation or vice-versa is simple and is described in the next chapter.

The installation for right-hinged doors is described in the following pages. The installation process for left-hinged doors is the same as for right-hinged doors, only with the GAT ECO.Lock and locker door rotated 180°.

3.6 Conversion for right- or left-hinged door

Converting the GAT ECO.Lock to suit a right or left-hinged locker door can be carried out easily by completing the following steps.

- ▶ Lift the lock electronics out of the lock housing.

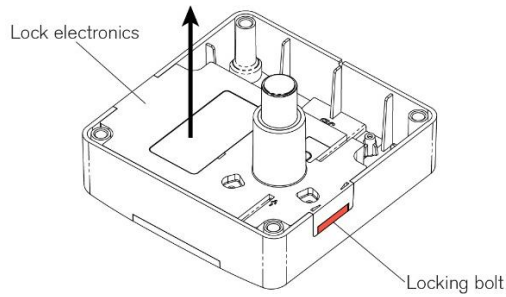

- ▶ Rotate the lock electronics 180°.

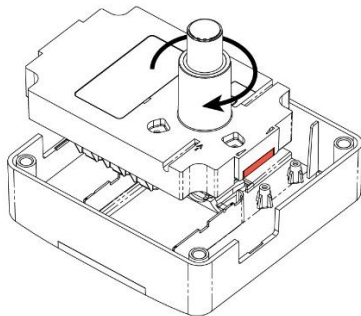

- ▶ Reinsert the lock electronics into the lock housing.

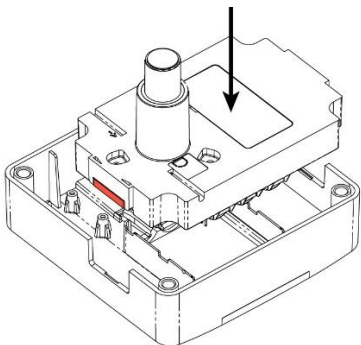

- The GAT ECO.Lock is now converted to the opposing locker hinge type.

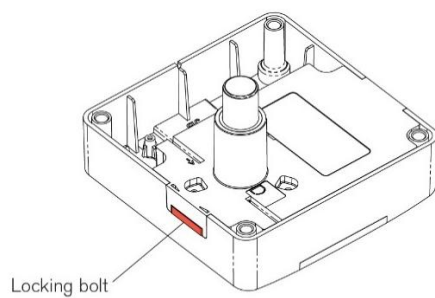

3.7 Requirements for the GAT ECO.Lock 715x variants (IP64)

The IP64 rated variants (GAT ECO.Lock 715x) are designed to be used in outdoor conditions. Please note the following information if operating the IP64 variants outdoors:

- > The IP64 protection rating means that the lock is protected against water splashing against it from any direction and completely protected against the ingress of dust.
- > The IP64 rating is only valid after the GAT ECO.Lock 715x has been installed correctly and the locker is locked. The rear side of the GAT ECO.Lock 715x does not have increased IP protection.
- > The ingress of water into the locker via the GAT ECO.Lock 715x can still occur after installation, e.g., if the locker is exposed to heavy rain for an extended period. In this case, the ingress of water is not considered a fault.
- > If the lockers are located where they are fully exposed to rain, it is recommended to install a "rain cover" (1) over the GAT ECO.Lock 715x button (2) to protect against water ingress as shown below.

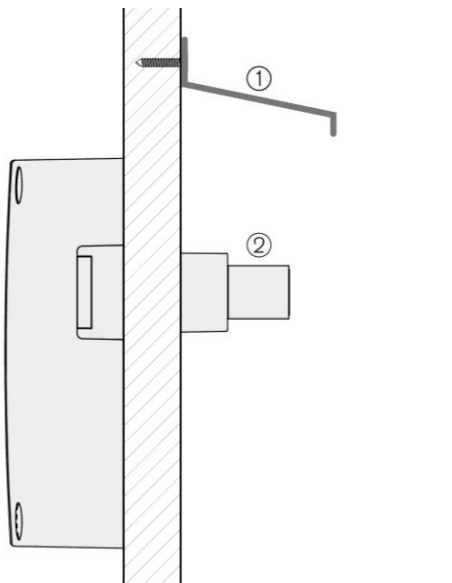

- > The operating temperature range of the recommended battery (see "6. TECHNICAL DATA") is -20 to 54 °C (-4 to 130 °F). If the lock is operating in cold temperatures, the battery capacity deteriorates as the temperature decreases and recovers again as the temperature increases.
- > It is also possible in cold temperatures for the button to become frozen. If this occurs, unlock the lock by reading the data carrier and knock lightly against the button.

3.8 Measurement diagrams for installation



All measurements in the following installation diagrams are in millimeters. Inches are provided in parenthesis for reference only.

3.8.1 Door width and thickness

The GAT ECO.Lock is suitable for locker doors with a maximum door leaf thickness of 28 mm (1.1 in).

When installing the GAT ECO.Lock into lockers with narrow doors, ensure that the lock housing does not contact the locker body when opening and closing the door (see below).

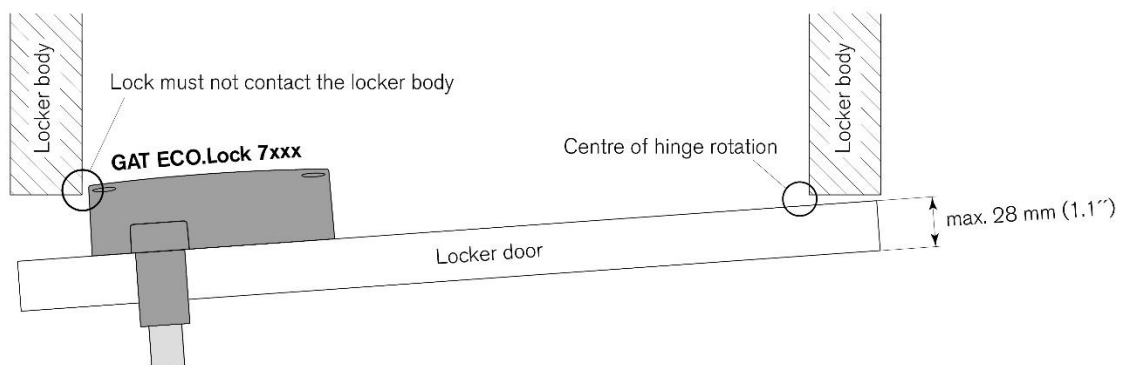
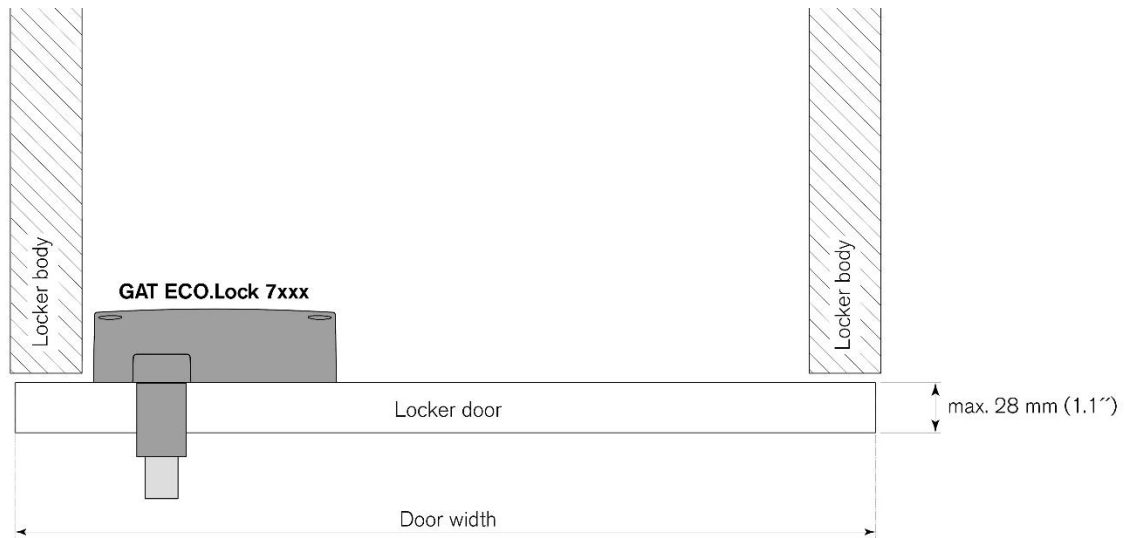

Figure 3.2 – Width and thickness of the locker door

3.8.2 Dimensions of the GAT ECO.Lock

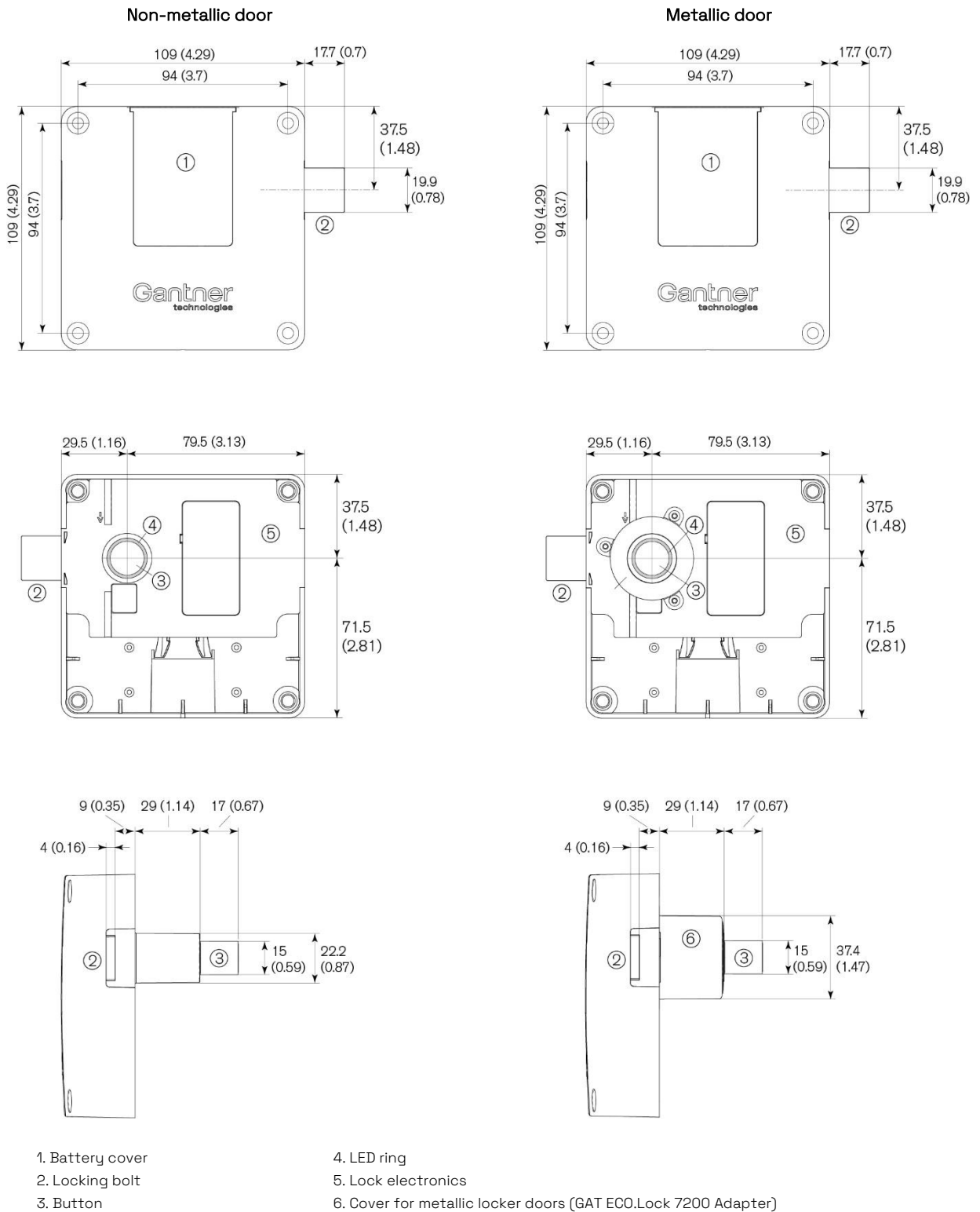

Figure 3.3 – GAT ECO.Lock dimensions and components

3.9 Installation in lockers with non-metallic doors

For lockers with non-metallic doors, the GAT ECO.Lock is mounted on the left or right inner-side of the locker door depending on whether the door is right or left-hinged. A drill hole is required in the locker door for the button of the GAT ECO.Lock.

NOTE! Before installing all locks in a new locker system, a test installation of one lock into a completed locker and a function check must be performed. See section “3.2. Test installation”.

3.9.1 Measurements for the button drill hole

A hole must be drilled into the locker door for the button. For non-metallic locker doors, the diameter of the button hole is 23 mm (0.9 in).

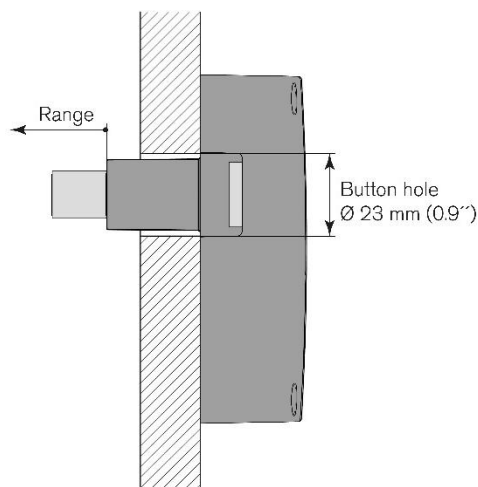

Figure 3.4 – Diameter of the button drill hole for non-metallic doors

The following diagram shows the position of the button drill hole in relation to the housing mounting holes.

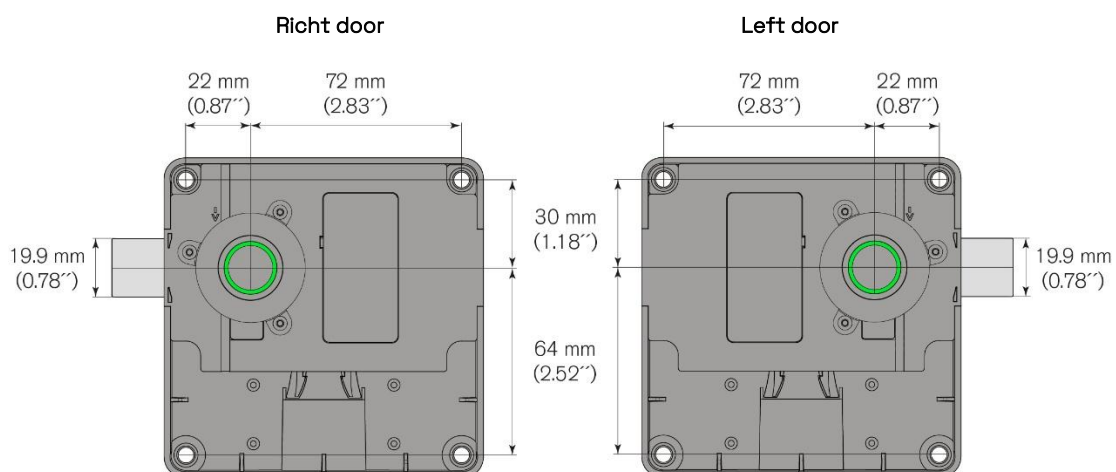

Figure 3.5 – Position of the button drill hole for non-metallic doors

3.9.2 Measurements for installation

NOTE! (A)

During installation, it is important to ensure that GAT ECO.Lock does not brush against the locker body when the locker door is opened. The distance of 4 mm (0.16 in) indicated between the lock housing and the locker body is valid for locker doors that are wider than 240 mm (9.45 in) and with a maximum door leaf thickness of 28 mm (1.1 in). For locker doors that do not adhere to these measurements, or for doors with an unfixed pivot point (depending on the type of hinge used), the distance between the lock and the body of the locker must be recalculated.

NOTE! (B)

To increase break-in protection, a security bolt can be installed on the locker body that inserts into the locker door when the door is closed.

Use the following measurements to position the button drill hole depending on whether the locker door is left or right hinged.

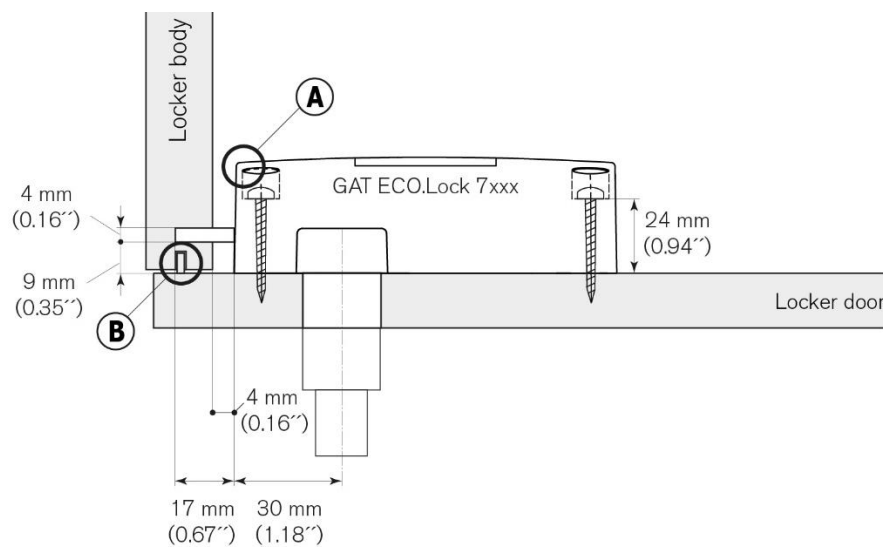

Figure 3.6 – Installation measurements for right-hinged doors

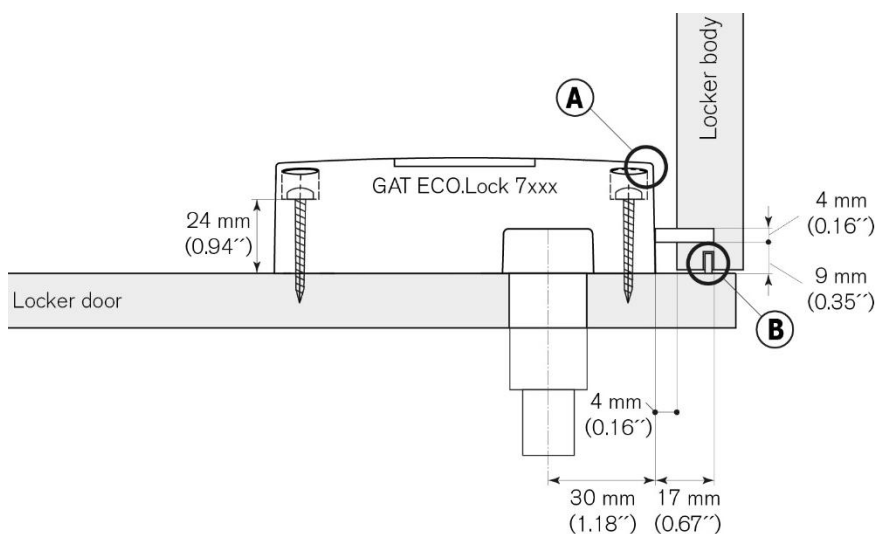

Figure 3.7 – Installation measurements for left-hinged doors

3.9.3 Installation instructions for non-metallic doors

Complete the following steps to install the GAT ECO.Lock into lockers with non-metallic doors.

- ▶ Drill 1 hole into the locker door for the lock button. Position the button hole according to the measurements in Figure 3.5 and Figure 3.6 (for right-hinged doors) or Figure 3.7 (for left-hinged doors).
- ▶ Mark out 4 mounting holes on the inside of the locker door for the lock housing. Position the holes according to the measurements in Figure 3.5 and Figure 3.6 (for right-hinged doors) or Figure 3.7 (for left-hinged doors).
- ▶ For harder doors, where the screws cannot be screwed in easily, the holes must be pre-drilled. If necessary, pre-drill the mounting holes for the lock housing.
- ▶ **NOTE!** Do not drill the holes for the screws completely through the door.
- ▶ If you are also using the optional GAT Lock Door Handle, this must be installed before the GAT ECO.Lock. See "3.12. Installing the door handle" for more information.
- ▶ Mount the GAT ECO.Lock onto the inside locker door using 4 screws. Hardware recommendation:
 - > For wooden or HPL doors: 5 x 35 mm (0.2 x 1.38 in) pan head wood screws.
 - > For wooden or HPL doors under heavy load or in public areas: screw-in or glue-in M5 threaded sleeves with 5 x 35 mm (0.2 x 1.38 in) cylinder head screws.
 - > The maximum allowed tightening torque of the screws is 2 Nm (1.47 lb-ft).
- ▶ If required, attach the door label(s) to the door front as shown in section "3.11. Attaching the door labels".

Testing:

- ▶ Check that there is no pressure applied to the button shaft of the GAT ECO.Lock in its assembled state, e.g., by a part of the locker door, as this could lead to malfunction.
- ▶ Ensure that the lock button is centrally aligned in the drill hole.
- ▶ Ensure that the GAT ECO.Lock housing does not contact the inside of the locker body when opening/closing the locker door.
- ▶ Ensure that the battery cover can open and is not hindered by other components.



See section "4. COMMISSIONING" for instructions on inserting the batteries and putting the GAT ECO.Lock into operation.

3.10 Installation in lockers with metallic doors

For lockers with metallic doors, the GAT ECO.Lock is mounted on the left or right inner-side of the locker door depending on whether the door is right or left-hinged. A drill hole is required in the locker door for the button of the GAT ECO.Lock.

NOTE! Before installing all locks in a new locker system, a test installation of one lock into a completed locker and a function check must be performed. See section “5.3. Functional testing”.

3.10.1 Measurements for the button drill hole

A hole must be drilled into the locker door for the button. For metallic locker doors, the diameter of the button hole is 38 mm (1.5 in). This is a larger diameter than for non-metallic doors, which is necessary to guarantee an undisturbed reading field. The GAT ECO.Lock 7200 Adapter is used to cover the hole.

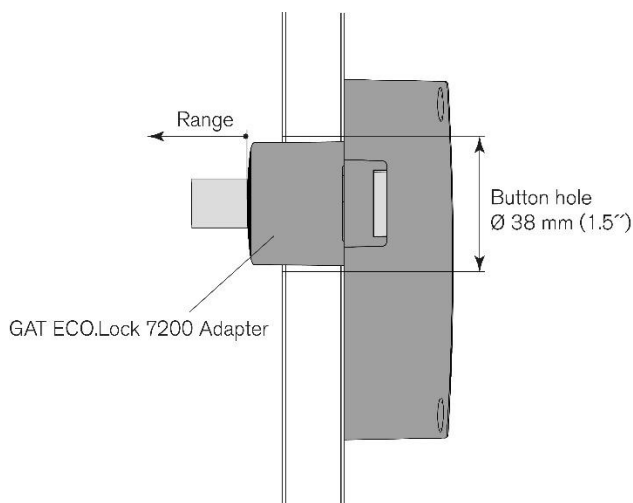

Figure 3.8 – Diameter of the button drill hole for metallic doors and mounting the GAT ECO.Lock 7200 Adapter

The following diagrams show the position of the button drill hole in relation to the housing mounting holes.

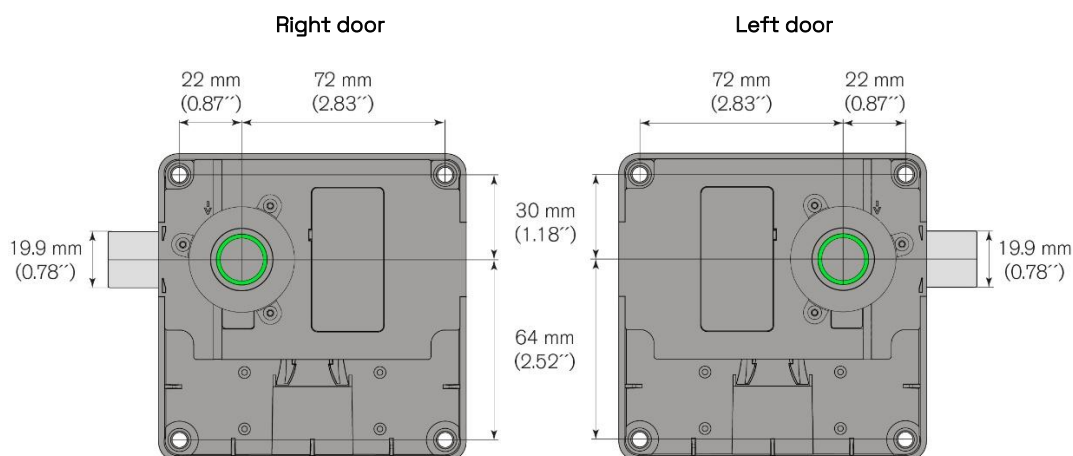

Figure 3.9 – Position of the button drill hole for metallic doors

3.10.2 Measurements for installation

When the GAT ECO.Lock is mounted on a single-wall metallic door, it is recommended to install the lock a corresponding distance away from the locker door, e.g. using a mounting bracket, as shown below in Figure 3.9. This installation method allows the lock to be mounted on the inside of the locker wall without the need to drill through the outside of the locker door.

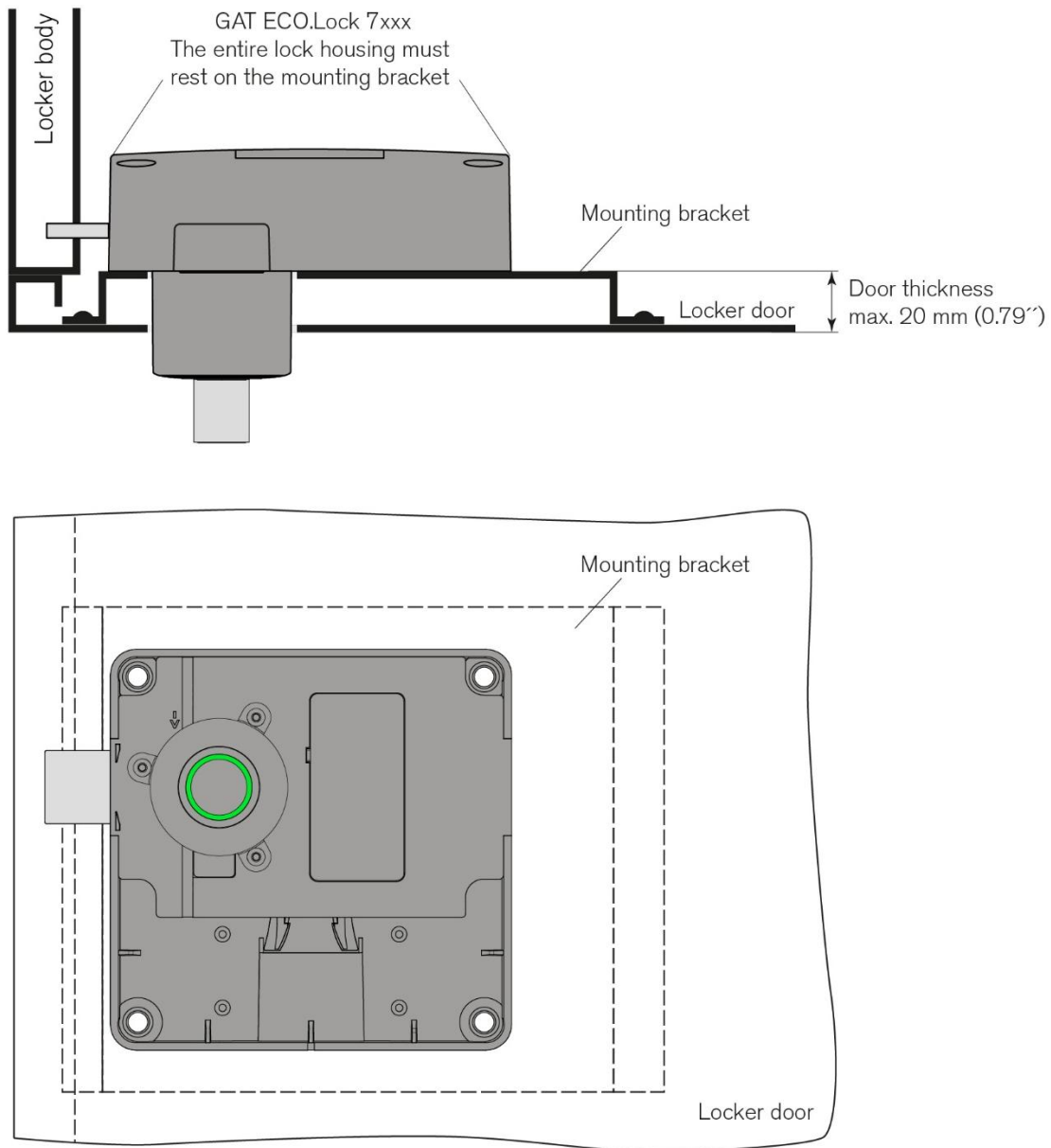

Figure 3.10 - Installation of the GAT ECO.Lock on a single-wall metallic door

When the GAT ECO.Lock is mounted on a double-wall metallic door, it can be mounted directly onto the door.

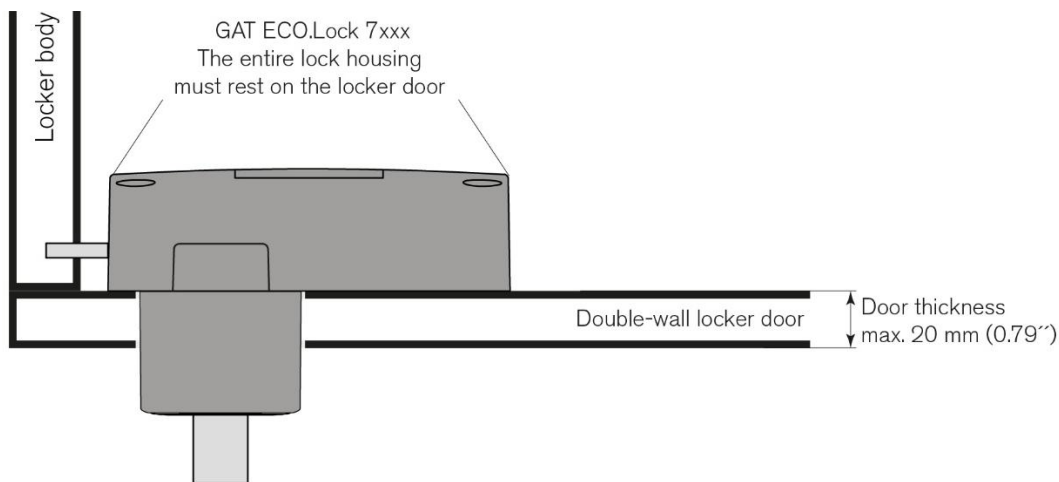

Figure 3.11 – Installation of the GAT ECO.Lock on a double-wall metallic door

NOTE! Die Türblattstärke (siehe vorige Bilder) darf 20 mm nicht übersteigen. Dickere Türen können zu Reichweiteneinbußen speziell bei größeren Datenträgern (z. B. Karten) führen, so dass diese nicht mehr zuverlässig gelesen werden können.

3.10.3 Installation instructions for metallic doors

Complete the following steps to install the GAT ECO.Lock into lockers with metallic doors.

- ▶ Mark out and drill 1 hole into the locker door for the lock button. Position the button hole according to the measurements in figure 3.9 and figure 3.6 (for right-hinged doors) or figure 3.7 (for left-hinged doors).
- ▶ Mark out 4 mounting holes on the inside of the locker door for the lock housing. Position the holes according to the measurements in figure 3.9 and figure 3.6 (for right-hinged doors) or figure 3.7 (for left-hinged doors).
- ▶ Attach the GAT ECO.Lock 7200 Adapter as shown in figure 3.8.
- ▶ Mount the GAT ECO.Lock onto the inside locker door using 4 screws. Use the correct screws according to the type of locker material, max. \varnothing 5 mm (0.2 in). The maximum allowed tightening torque of the screws is 2 Nm (1.47 lb-ft).
- ▶ If required, attach the door label(s) to the door front as shown in section “3.11. Attaching the door labels”.

Testing

- ▶ Check that there is no pressure applied to the button shaft of the GAT ECO.Lock in its assembled state, e.g., by a part of the locker door, as this could lead to malfunction.
- ▶ Ensure that the lock button is centrally aligned in the drill hole.
- ▶ Ensure that the GAT ECO.Lock housing does not contact the inside of the locker body when opening/closing the locker door.
- ▶ Ensure that the battery cover can open and is not hindered by other components.



See section “4. COMMISSIONING” for instructions on inserting the batteries and putting the GAT ECO.Lock into operation.

3.11 Attaching the door labels

Door labels can be attached to the front of the locker door to display the locker number or provide instructions for use. See chapter “2.4. Door labels” for information on some of the labels available for the GAT ECO.Lock.

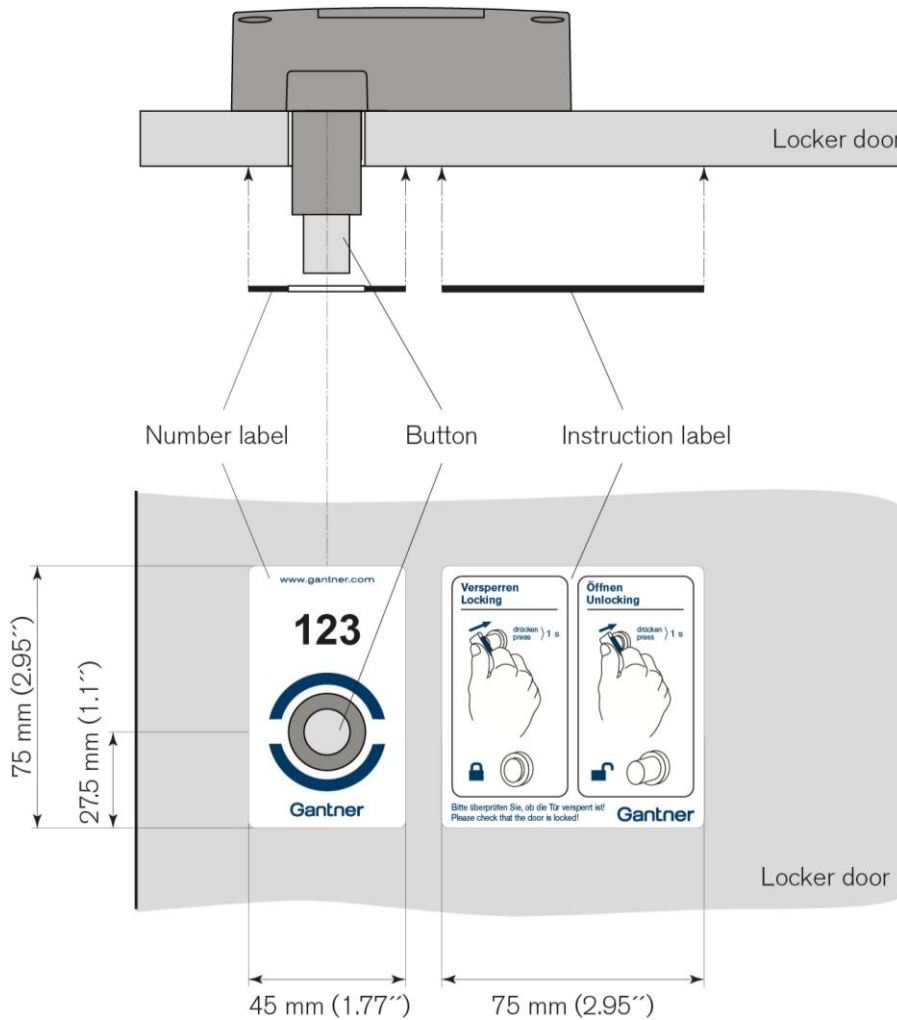
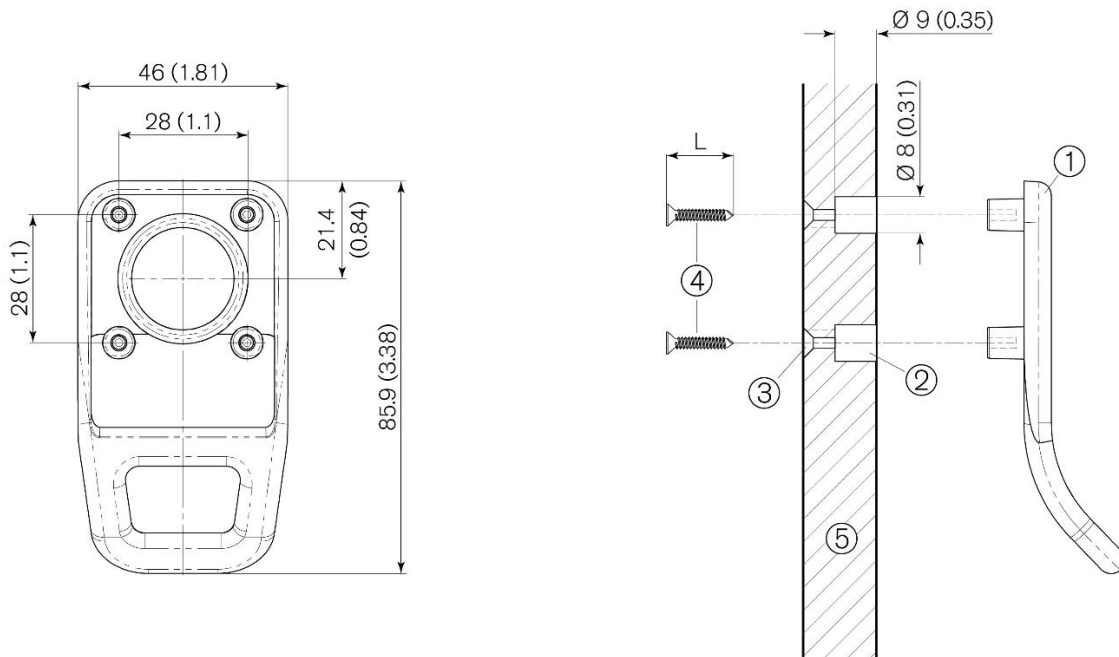

Figure 3.12 – Label attachments for right-hinged door

3.12 Installing the door handle

The optional **GAT Lock Door Handle** (see also "2.6. Door handle (optional)") can be mounted onto the locker door to assist door opening. The door handle is installed over the button of the GAT ECO.Lock using four screws.

NOTE! The door handle cannot be used with metallic locker doors, which have a 38 mm drill hole for the GAT ECO.Lock 7200 Adapter.



1. GAT Lock Door Handle
2. Door outer side blind hole (4 x)
3. Door inner side mounting screw hole (4x)
4. Mounting screws (Ø 3.5 mm sheet metal screws)
5. Locker door

Figure 3.13 – Installation of the GAT Lock Door Handle

Complete the following steps to install the GAT Lock Door Handle:

- ▶ On the door outer side, drill 4 blind holes (2), diameter 8 mm and depth 9 mm, around the lock button hole according to the measurements in the previous image.
- ▶ On the door inner side, drill 4 countersunk holes for the mounting screws. These holes must be located centrally in the blind holes.
- ▶ Insert the GAT Lock Door Handle into the drilled holes on the door outer side.
- ▶ Fasten the GAT Lock Door Handle with the mounting screws (Ø 3.5 mm sheet metal screws).
- ▶ **NOTE!** The screw length L must be 2 mm shorter than the door thickness.
- ▶ If desired, a label with the locker number can be attached to the GAT Lock Door Handle (see example). The label can be printed with a customer-specific number, font, and color. The maximum dimensions of the label are 37.7 x 15.7 mm (typical 37 x 15 mm), corner radius 1 mm (1.48" x 0.62", corner radius 0.04"). Please contact GANTNER or your sales partner to organize label printing.
Please contact GANTNER or your sales partner to organize label printing.



- The GAT ECO.Lock can now be mounted onto the inner side of the locker door (see chapter “3.9.3. Installation instructions for non-metallic doors”).

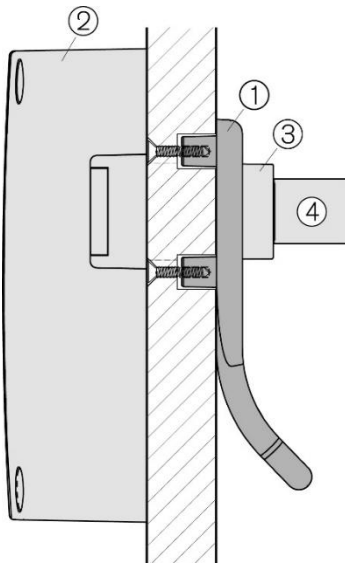

1. GAT Lock Door Handle
2. GAT ECO.Lock
3. GAT ECO.Lock button shaft
4. GAT ECO.Lock button

Figure 3.14 – Installed GAT Lock Door Handle and GAT ECO.Lock in assembled condition

4 COMMISSIONING

4.1 Target group

This chapter provides information for technicians responsible for putting the GAT ECO.Lock into operation. A base knowledge of electronics is assumed. Previous knowledge of the GAT ECO.Lock is not required.

4.2 Battery lock configuration set

To configure and maintain the battery locks of your locker system and to perform important system functions, GANTNER provides four configuration sets to suit the different GAT ECO.Lock variants (see chapter "2.3. GAT ECO.Lock").

4.2.1 GAT ECO.Basic Set

The GAT ECO.Basic Set is intended for all GANTNER battery locker locks without CardNET function and OSS Standard Online function. Two GAT ECO.Basic Sets are available to suit the required RFID technology:

- > GAT ECO.Basic Set **BA** lite – Part No. 1110090. Suitable for the GAT ECO.Lock 7xxx **BA** locks.
- > GAT ECO.Basic Set **FD** lite – Part No. 1110092. Suitable for the GAT ECO.Lock 7xxx **F/ISO** locks.

NOTE! To maintain the security of the locker system, ensure that the GAT ECO.Basic Set is kept in a secure location protected from unauthorized use.

The following items are included in the GAT ECO.Basic Set lite.

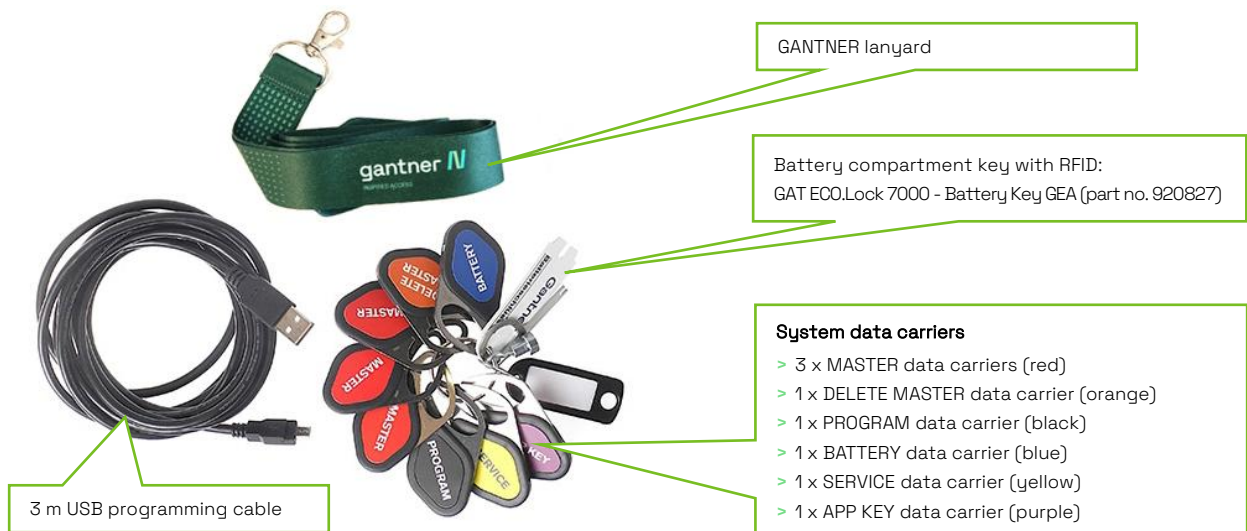

Optionally available: OPEN MASTER data carrier

This optional system data carrier is available to order separately. In contrast to the MASTER data carrier, the OPEN MASTER data carrier can only unlock a locker but not lock it again.

Optionally available: GAT ECO.Lock 7000 Battery Key metal (part no. 616526)

Battery compartment key made of metal without RFID functionality. This key is not included in the Basic Set and is available separately on request. This key is used to open the battery compartment of a GAT ECO.Lock. It has no BATTERY Key functionality like the GAT ECO.Lock 7000 – Battery Key GEA (part no. 920827).

4.2.2 GAT DL 300 Master Key Set

To configure the GANTNER battery locker locks with CardNET function or OSS Standard Online function, GANTNER offers the following configuration sets to suit the required RFID technology:

- > GAT DL 300 Master Key Set (ISO 15693) – Part No. 253022
- > GAT DL 300 Master Key Set (ISO 14443) – Part No. 1105331

The following system data carriers, in the form of RFID chip cards, are included in the set.

PROGRAMMING Data Carrier



BATTERY Data Carrier



DELETE Data Carrier



WiNET Data Carrier



DEMOUNTING Data Carrier



Optional data carriers:

COMMUNICATION Data Carrier



DATA SECURE Data Carrier



NOTE! To maintain the security of the locker system, ensure that the GAT DL 300 Master Key Set is kept in a secure location protected from unauthorized use.

4.3 Power supply

4.3.1 Battery information

The GAT ECO.Lock is powered by three 1.5 V AA alkaline batteries (see "6. TECHNICAL DATA"). The lifespan of the battery depends on the number of locking cycles (usage frequency of the lock) and the ambient conditions. All three batteries must be replaced when the battery voltage becomes too low. If the battery condition becomes too weak, the locker can no longer be locked.



A low battery condition is indicated by the LED ring flashing red five times and five beeps being emitted during an unlocking or locking attempt.

NOTE! Always use the GANTER approved battery to power the GAT ECO.Lock (see "6 TECHNICAL DATA").

4.3.2 Inserting the batteries

Before putting the GAT ECO.Lock into operation, the batteries must be inserted into the battery compartment. In order to access the battery compartment, the battery cover on the back of the housing must be removed, which is done using the battery key that is included in the GAT ECO.Basic Set (see 4.2.1. GAT ECO.Basic Set). The GAT ECO.Lock 7000 – Battery Key GEA (part no. 920827) made of metal is also available as an option, with which the battery compartment can also be opened.

NOTE! To avoid unnecessary battery usage, insert the batteries directly before the GAT ECO.Lock is installed.

- ▶ Insert the battery cover key into the slot on the underside of the GAT ECO.Lock.

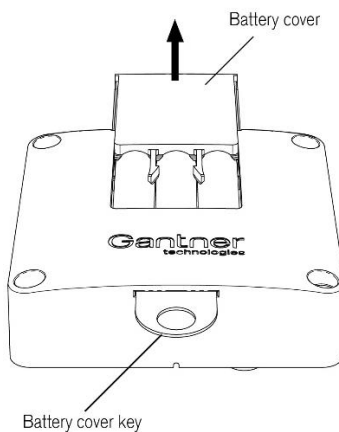

Figure 4.1 – GAT ECO.Lock battery compartment

- ▶ Push the battery cover key into the slot until the battery cover is released.
- ▶ Remove the battery cover.
- ▶ Ensure that the battery polarity is correct. The polarity differs depending on whether the lock is mounted on a left or right-hinged door (see following diagram).

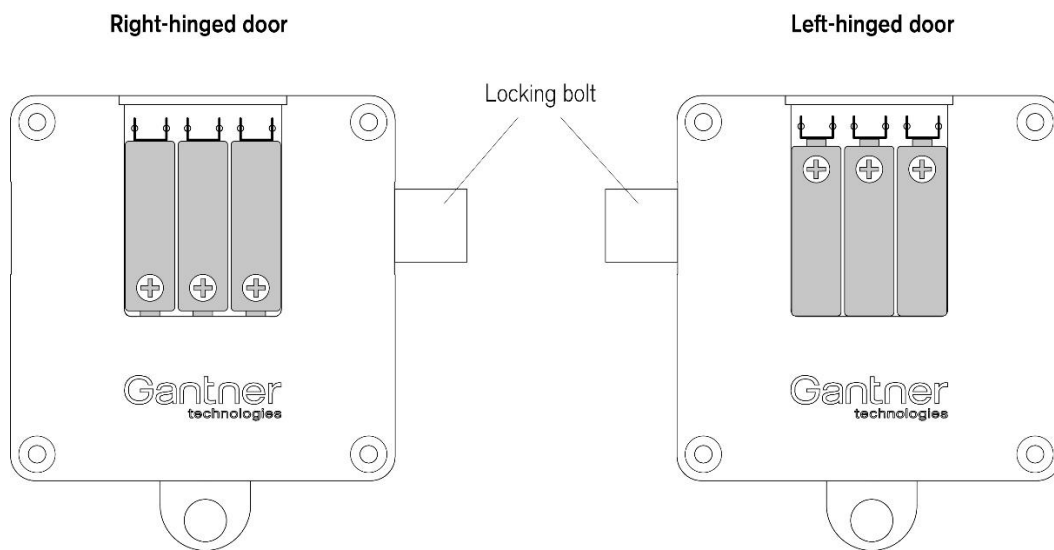

Figure 4.2 – Correct battery polarity

- ▶ Press the batteries down into the compartment until they lock into place.
- ▶ Slide the battery cover back onto the battery compartment until it clicks into place.
 - If installing the batteries in the GAT ECO.Lock for the first time, the process is now complete.
 - If the lock has already been used and the batteries are being replaced, the lock must be activated using the battery cover key or the BATTERY data carrier from the appropriate battery lock configuration set (see the following section).

4.3.3 Replacing the batteries

The batteries of the GAT ECO.Lock must be replaced when the LED ring flashes red five times and five beeps are emitted during a locking attempt. In this state, the GAT ECO.Lock can no longer be locked until the batteries are replaced. Do not operate the GAT ECO.Lock while replacing the batteries.

Following battery replacement, the GAT ECO.Lock must be returned to its normal operating mode using the RFID BATTERY data carrier or battery cover key, which is included in the configuration set (see “4.2. Battery lock configuration set”). In addition, the time must be reset after each battery change (see the “GANTNER Battery Locker Locks Function Manual” for instructions).

- ▶ Follow the instructions described in section “4.3.2. Inserting the batteries”.
- ▶ Press the lock button of the GAT ECO.Lock in using the BATTERY data carrier.
 - The lock confirms the successful reading of the data carrier with a short melody and a quick flash of the LED in green.
 - The lock returns to its normal operating mode.

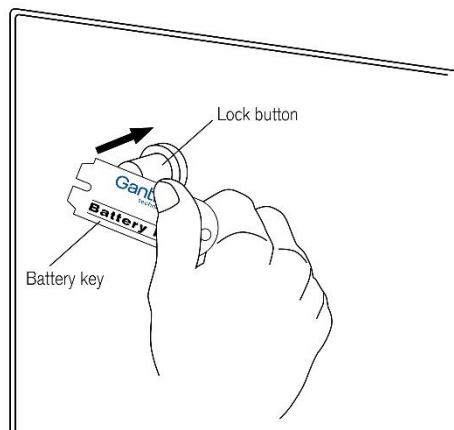

Figure 4.3 – Activating the GAT ECO.Lock with the RFID battery cover key



Always dispose of used batteries in an environmentally friendly way, e.g., at an electronic waste recycling facility.

4.3.4 Emergency power adapter

If the batteries in the GAT ECO.Lock become completely empty and the corresponding locker is locked, the locker is unable to be opened. For this situation GANTNER offers the GAT ECO.EPS 7000 (Part No. 963733) emergency power adapter. The GAT ECO.EPS 7000 in combination with an external USB power source (e.g., USB power pack) is used to temporarily supply the GAT ECO.Lock with power thereby allowing the locker to be opened and the batteries to be exchanged.

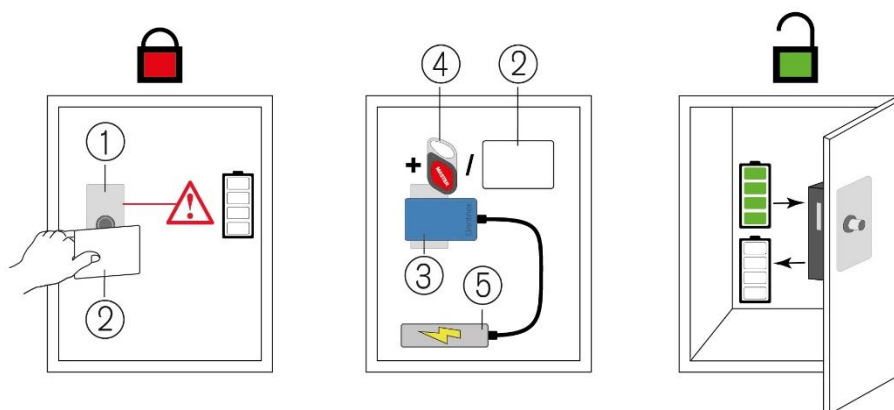

1. GAT ECO.Lock
2. User data carrier
3. GAT ECO.EPS 7000
4. MASTER data carrier
5. USB power pack

Figure 4.4 – Application of the GAT ECO.Lock with emergency power adapter



Detailed instructions can be found in the document that is included with the GAT ECO EPS 7000 => VB_GAT ECOEPS-7000-EN+EN.

4.4 USB connection

For the connection to a computer with Windows® operating system (Windows® 7 and upwards) a Micro-B USB port is located on the opposite side of the GAT ECO.Lock to the locking bolt. The USB port location on the side of the lock allows configuration to occur even while the lock is installed in a locker.

NOTE! The maximum cable length between the GAT ECO.Lock and a computer is 5 m.

After the USB cable is connected, the SERVICE data carrier (see "4.2. Battery lock configuration set") is used to put the GAT ECO.Lock into configuration mode. However, if the lock is still in the default delivery state, the SERVICE data carrier is not required to activate configuration mode. In this mode the lock can be configured using the respective configuration software (GAT ECO Lock Configurator, MoLa App or GAT DL Analyzer).



The configuration software is available to download from the GANTNER website (login required). Further information on configuring the lock is available in the "GANTNER Battery Locks Function Manual".

To configure the GAT ECO.Lock via PC/laptop.

- ▶ Start the configuration software on the PC/laptop.
- ▶ Connect the USB cable (type-A end) to a spare USB port on the PC/laptop.

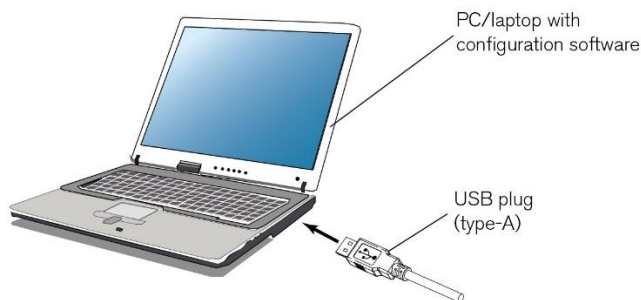

- ▶ Connect the Micro-B connector of the USB cable into the USB port on the GAT ECO.Lock.

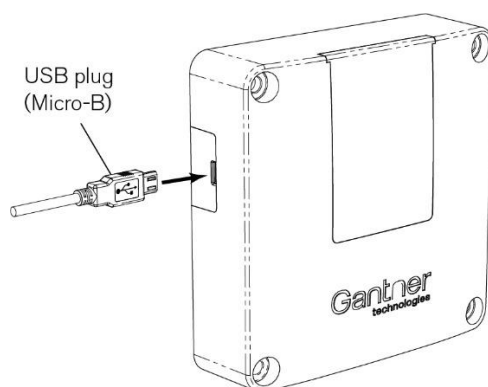

- The LED ring flashes alternating red/green after connecting to the computer.
- When the GAT ECO.Lock is connected to the computer for the first time, the driver is automatically installed, and the lock recognized.



If the automatic driver installation does not work and you need the driver, it is available to download from the GANTNER partner website (login required) or via the direct link (QR code) on the Basic Set documentation.

▶ Activate configuration mode:

- For locks **without** CardNET function or OSS Standard Online function, press the lock button in using the SERVICE data carrier.
- For locks **with** CardNET function or OSS Standard Online function, press the lock button in using the PROGRAMMING data carrier from the GAT DL 300 Master Key Set or the optional COMMUNICATION data carrier.

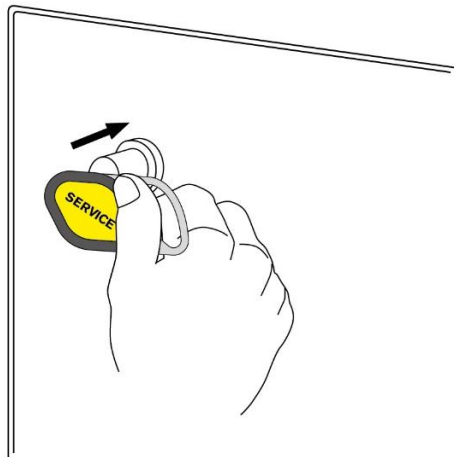

- The GAT ECO.Lock enters configuration mode. The LED ring slowly pulses green to indicate this state.

5 MAINTENANCE

This chapter contains information for the cleaning personnel and service technicians responsible for the cleaning and maintenance of the GANTNER battery locks or lockers.

ATTENTION! The instructions described in this chapter may only be carried out by suitably trained personnel. The warnings in this chapter must be observed and followed during functional testing, cleaning, and maintenance.

5.1 Cleaning

Regular cleaning of the locker components ensures that the locker system remains in good condition and the correct working order is maintained.

NOTE! Do not use cleaning benzene, diluents, or other abrasive detergents. In addition, the components must not be cleaned using a high-pressure or steam cleaner otherwise damage can occur!

Complete the following steps to clean the locker:

- ▶ Wipe off dirt and dust using a soft, lint-free, dry cloth.
- ▶ For extreme dirt, clean the locker components using a damp cloth. Do not allow any moisture to enter the inner parts of the lock.



Detailed cleaning instructions can also be found in the Gantner document "DK_GAT_Reinigungshinweise-DE+EN".

5.2 Maintenance

The components of the GANTNER battery locks are maintenance-free, i.e., maintenance of the mechanical parts is not required. Should a malfunction be detected during functional testing that cannot be remedied, the corresponding faulty part(s) must be replaced.

5.3 Functional testing

To ensure that the locker locks are functioning correctly, periodically test the functionality of the locker doors and lock components.

Frequency

- > After every 1000 locking operations, or,
- > If the locking function of a locker door is impaired

Instructions

- ▶ Close the locker door.
 - The door must shut without increased effort. Readjust the door (see below) if this does not happen.
- ▶ Lock the door by pressing the button of the lock in using a valid data carrier.
 - The locker door must lock. If it does not, check that the data carrier authorization is valid.

- ▶ Unlock the door by pressing the button of the lock in using a valid data carrier.
 - The locker door unlocks and must open without resistance. If the door gets jammed or is stiff, it must be readjusted (see below).

Adjusting the locker door

If a problem occurs when closing or opening the cabinet door during the function check as described under "Instructions":

- ▶ Adjust the position of the locker door using the dimensions in chapters "3.8. Measurement diagrams for installation", "3.9. Installation in lockers with non-metallic doors" and "3.10. Installation in lockers with metallic doors".
- ▶ If the door does not adjust properly, mount it in a different position.
- ▶ If the door is damaged, replace the door with a new door.
- ▶ If the GAT ECO.Lock is damaged, it must be replaced.

5.4 Disposal



- > Always dispose of the GANTNER battery lock and the associated components at an electronic waste recycling facility in accordance with the local regulations (e.g., European Directive 2002/96/EC).
- > Recycle defective or used batteries in accordance with the local regulations (e.g., European Directive 2006/66/EC).
- > Observe local regulations for the separate disposal of batteries.
- > Recycle packaging in an environmentally friendly manner.

6 TECHNICAL DATA

6.1 Power supply

Power supply	3 x 1.5 V alkaline batteries, type AA
Gantner approved batteries	Energizer Industrial EN91 (part no. 308819)
Battery lifespan	Up to 5 years* or 30,000 cycles with alkaline batteries at room temperature * Depending on usage, configuration, and environmental conditions

6.2 Reading field

Reader types

- GAT ECO.Lock 7xxx BA:	LEGIC advant reader (LEGIC prime, LEGIC advant, Combi data carrier, MIFARE Classic, MIFARE DESFire, MIFARE Ultralight, ISO 15693, HID iClass® - CSN (UID))
- GAT ECO.Lock 7xxx F/ISO:	MIFARE / ISO 15693 reader (MIFARE Classic, MIFARE DESFire, MIFARE Ultralight, ISO 15693, LEGIC advant (UID), HID iClass® - CSN (UID))
- GAT ECO.Lock 7xxx F/ISO ICLS:	MIFARE / ISO 15693 reader (MIFARE Classic, MIFARE DESFire, MIFARE Ultralight, ISO 15693, LEGIC advant (UID), HID iClass® - PACS Data, HID iClass® Seos – PACS Data) See "2.3 GAT ECO.Lock " for details on the RFID technologies. NOTE! It is recommended to have customer specific data carriers approved by Gantner before use.

RFID reading field

- Frequency:	13.56 MHz
- Max. transmission power:	< 500 mW
- Range:	5 to 35 mm (0.2 to 1.38 in)* * depending on the installation and data carrier

BLE

- Frequency:	2.445 MHz
- Frequency range:	min. 2.4 – max. 2.4835 MHz
- Standard:	Bluetooth 5.2 compliant
- Output power TX:	+6 dBm
- Max. transmission power:	-20 dBm to 4 dBm
- Range in indoor areas:	5 – 10 m

6.3 Memory and time management

Data storage	EEPROM with capacity for 150 bookings, data retained during battery change
Internal clock	Quartz-controlled, real-time clock

6.4 Control and display elements

Control element	Button
Display element	LED ring (multi-colored) for status indication

6.5 Interface

Interface type	USB 2.0
Interface connection	USB Typ Micro-B

6.6 Housing

Material	Plastic (PC), halogen-free, V0
Color	Dark gray
Weight	Approx. 400 g (14 oz)
Dimensions	109 x 109 x 33 mm (4.3 x 4.3 x 1.3 in)
Break-in resistance capability	DIN 4547-2 class C

6.7 Environmental conditions

Permitted ambient temperature

- Indoor model:	0 °C to 55 °C (32 °F to 131 °F)
- Outdoor model:	-20 to +55 °C (-13 °F to 131 °F)

Protection type

- Indoor model:	IP 52 (when installed)
- Outdoor model:	IP 64 (when installed, door closed and locked)

Environment class based on VdS 2110

- Indoor model:	II (conditions in indoor areas)
- Outdoor model:	III (conditions in protected outdoor areas)

Compliance

CE, UKCA, FCC, IC (7020 NW F/ISO and 7020 NW F/ISO ICLS)

NOTE! An overview of all approvals can be found on the Gantner website.

Note:

This manual is valid as of August 28th 2025. It is subject to change.
Amendments can be made without prior notice at any time!



gantner **W**

INSPIRED ACCESS

SALTO **W**ECOSYSTEM

SCAN FOR CONTACT

© 2025 Gantner
Gantner reserves the right to change technical specifications,
designs and services without prior notice.
Photos: GANTNER / SALTO Systems / Shutterstock

